



ACLIMATRON 107
USER MANUAL

ACLIMATRON 107

User's Manual

Ver: 1.2
Revised; 05/08/07





ACLIMATRON 107 User's Manual

The Aclimatron 107 is a controller especially designed for cooling poultry houses. It is possible to set the cooling temperature and cooling on time. The off time will be reduced as the measured temperature rises above the cooling temperature.

It is possible to set the maximum and minimum off time.

It is possible to set a humidity set point that when reached will turn off the cooling system.

The Aclimatron comes with one temperature sensor.

A humidity sensor may be connected to the unit (optional).

The Aclimatron has 3 built in dry contacts. These contacts can be program to work either according to a set temperature or humidity set point

It is possible to setup the unit to supply electricity to an electrical valve for the cooling system. The power supplied to the tap can be setup as 12VAC/DC or 24VAC/DC.

INSTALLATION

1. Carefully unscrew the two screws on the front panel.
2. Open the front cover.
3. Connect the box to the wall at a dry place.
4. Connect the Temperature Sensor.

It is possible to connect the Temperature Sensor up to 100 meters away from the controller by using a standard two-wire cable.

5. Setup the proper electrical output to be used to control the cooling system electrical tap (see drawing).
6. If you have fans in the poultry house, it is possible to connect them to the one of the dry contacts located in the Aclimatron 107 (see drawing).
7. If you have a heating system in the poultry house, it is possible to connect it to the one of the dry contacts located in the Aclimatron 107 (see drawing)..
8. Close the front panel with the two screws.

It is possible to connect a Humidity Sensor, H-701 to the Aclimatron 107 to avoid cooling in high humidity.

OPERATION

Connect the Aclimatron 107 to the power supply. While the temperature sensor calibrates itself, ---- will appear on the display.

Once the temperature sensor is fully calibrated the temperature reading will appear on the display.



Front panel and display

On the left hand side of the front panel are 7 lights, each light represents a different function.

Cool Temp:

Enter here the temperature that when reached in the house will bring the cooling system into operation. The system will run as explained below.

Min off time:

Minimum off time is set in minutes. This is the minimum amount of time the cooling system will be off during its cycle mode.

Max off time:

Maximum off time is set in minutes. This is the maximum amount of time the cooling system will be off during its cycle mode.

On time:

On time is set in seconds. This is the length of time the cooling system will run while its in the cycle mode.

The Aclimatron 107 system was especially designed for the cooling control of poultry and hog houses. When the measured house temperature is higher than the **Cool temp** , the Aclimatron 107 will start its programmed cycle mode. It will open the electrical valve connected to the cooling system for the set amount of time as set in the **On time** function. The **Max off time** will be used as long as the inside temperature is equal to the **Cool temp** setting. For every one degree rise in temperature above this setting the **Max off time** will be reduced by two minutes. As the house temperature continues to rise the **Max off time** will be reduced until the **Min off time** is reached. Example: Cool temp is set to 28°: On time set to 30 seconds: Minimum off time set to 1 minute: Max off time set to 20 minutes

Humidity set point (not shown on front panel)

It is possible to set a maximum humidity setting that once reached will turn off the cooling system.

1. Enter the Cool Temperature setup.
2. Press together + and – buttons.

Enter the maximum humidity setting allowed in the house. If the humidity rises above this setting the cooling system will shut down.



Example of how the cooling system runs

Cool Temp = 28°

On time = 30 seconds

Minimum off time = 1 minute

Maximum off time = 20 minutes

House temperature	On Time	Minimum off time	Maximum off time
28°	30 seconds	1 minute	20 minutes
29°	30 seconds	1 minute	18 minutes
30°	30 seconds	1 minute	16 minutes
33°	30 seconds	1 minute	10 minutes
36°	30 seconds	1 minute	4 minutes
38°	30 seconds	1 minute	1 minute

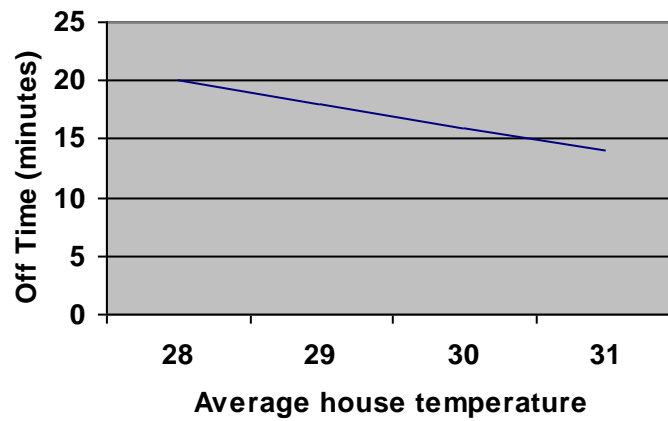

Set 1:

Set 1 is the temperature/humidity set point for the dry contact relay number 1. This dry relay can be set to run according to either temperature or humidity.

The relay can be used as either NO or NC.

The relay can be setup to run in one of 4 different modes. See table.

When the set temperature/humidity set point is reached the relay will open/close.

Set 2:

Set 2 is the temperature/humidity set point for the dry contact relay number 2. This dry relay can be set to run according to either temperature or humidity.

The relay can be used as either NO or NC.

The relay can be setup to run in one of 4 different modes. See table.

When the set temperature/humidity set is point reached the relay will open/close.

Set 3:

Set 3 is the temperature/humidity set point for the dry contact relay number 3. This dry relay can be set to run according to either temperature or humidity.

The relay can be used as either NO or NC.

The relay can be setup to run in one of 4 different modes. See table.

When the set temperature/humidity set point is reached the relay will open/close.

To setup the way the relay will operate follow the steps below.

1. Press on the + button until the **Set 1** light is on.
2. Press on the **Prog** button.
3. Press simultaneously on the + and – button. On the display will appear T-C (temperature cold).
Press again on the – button and the letters T-H (temperature hot) will appear.
Press again on the – button and the letters H-D (humidity low) will appear.
Press again on the – button and the letters H-r (humidity high) will appear.

Chose the correct mode for the set relay and press on the enter button,

Relay mode setup

Mode	Operation
T-C = Temperature cold	In this mode the relay will come into operation when the temperature sensor reading rises <u>above</u> the set point.
T-H = Temperature hot	In this mode the relay will come into operation when the temperature sensor reading drops <u>below</u> the set point.
H-D = Humidity low	In this mode the relay will come into operation when the humidity sensor reading drops <u>below</u> the set point.
H-r = Humidity high	In this mode the relay will come into operation when the humidity sensor reading rises <u>above</u> the set point.

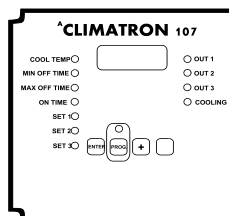

On the right hand side of the front panel are 4 lights, each light represents a different output. When the according output is in use the light will go on.

Output 1:

Output 1 is the light representing relay 1.

Output 2:

Output 2 is the light representing relay 2.

Output 3:

Output 3 is the light representing relay 3.

Cooling:

When the cooling system is in operation the cooling light will come on.



Programming the Aclimatron 107

It is possible to see and change the data for each function on the Aclimatron's display. Press once on the + button and the first light on the left hand side of the front panel will light up. The information relevant to this function is now shown on the display. It is now possible to change the information for this function. See Changing Data section.

Each additional press on the + button will toggle through the 7 different functions. If nothing is done for a period of 20 seconds, the display will automatically return to the main temperature display.

Changing data

1. Press on "+" or "-" button until the requested data light is reached.
2. Press on the "**Prog**" button. Both the light of the chosen data and the **Prog** light will start to blink.
3. Press on "+" or "-" until the requested value is reached.

If you keep pressing on the "+" or "-" button for over 2 seconds, the displayed data will change automatically.

4. Press on "Enter" to enter the requested data to the controller's memory.

The data light will stop blinking.

Installation

It is possible to setup the unit to supply electricity to an electrical valve for the cooling system. The power supplied to the tap can be setup as 12VAC/DC or 24VAC/DC.

Power supply	Connector (from left to right)
Main power supply input (220V)	Connectors 1,2,3
To create 12V for power output	Short between connectors 4 and 6 Short between connectors 5 and 7
To create 24V for power output	Short between connectors 5 and 6
Output power supply for tap	Connectors 8 and 9
For AC power supply output	Short between connectors 11 and 12
For DC power supply output	Short between connectors 11 and 13

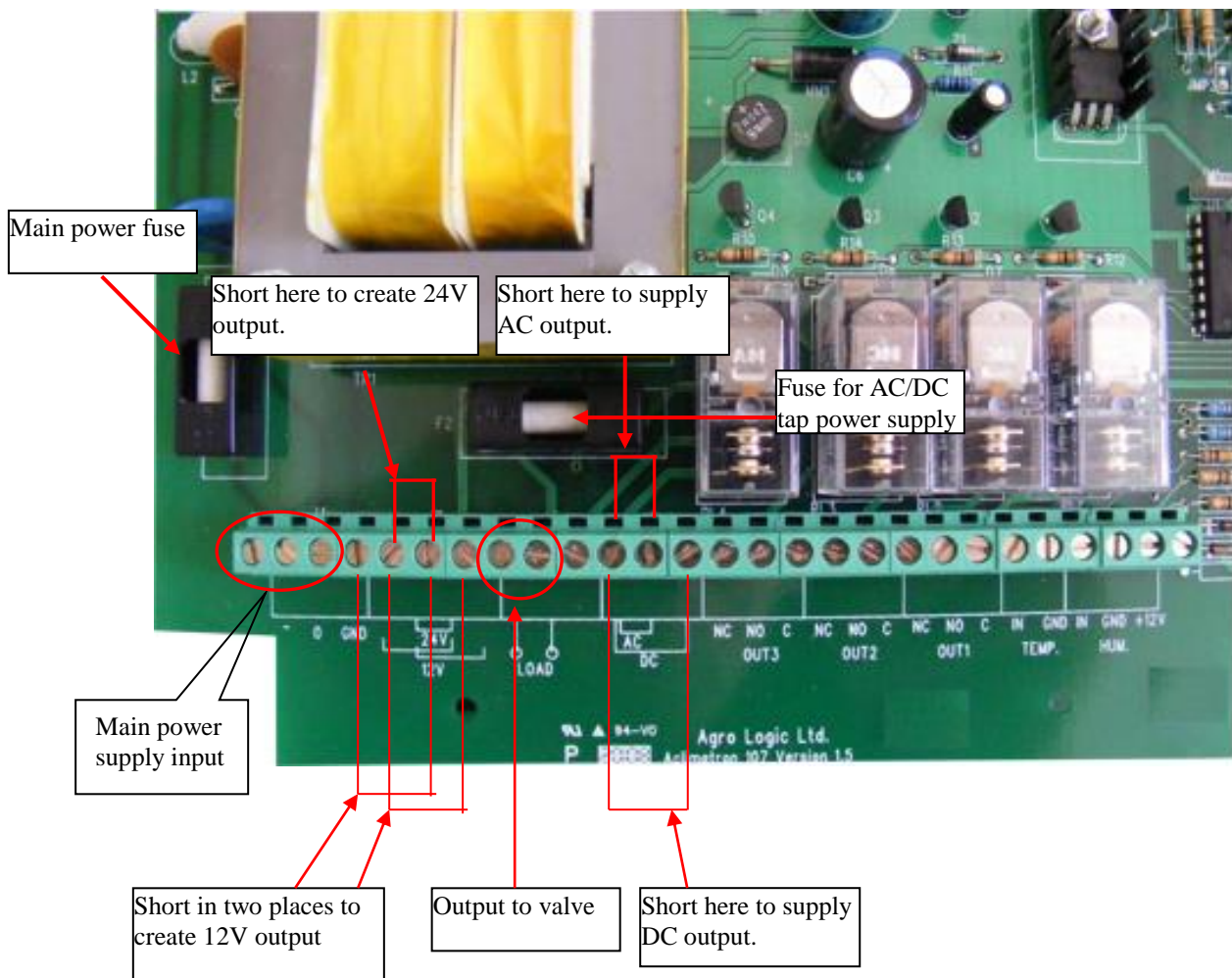



TROUBLESHOOTING

Problem	Solution
The cooling light is on but the cooling valve is not responding.	<ol style="list-style-type: none">1. <u>Disconnect the unit from the 220V.</u>2. Check the internal fuse.3. Check that the cooling valve is not malfunctioning.
The temperature display reading is 88.8	<ol style="list-style-type: none">1. Check the temperature sensor in the house. Be sure its is properly connected.2. Connect a new sensor
The temperature display reading is 99.9	<ol style="list-style-type: none">1. Check the temperature sensor in the house. Be sure its is properly connected.2. Check to see that there is no short on the sensors wiring.3.. Connect a new sensor